

## Description

The DL0504PCLV is a bi-directional TVS diode, utilizing leading monolithic silicon technology to provide fast response time and low ESD clamping voltage, making this device an ideal solution for protecting voltage sensitive high-speed data lines. The DL0504PCLV has an ultra-low capacitance with a typical value at 0.2pF, and complies with the IEC 61000-4-2 (ESD) with  $\pm 25\text{kV}$  air and  $\pm 20\text{kV}$  contact discharge. The small size, ultra-low capacitance and high ESD surge protection make DL0504PCLV an ideal choice to protect cell phone, digital video interfaces and other high speed ports.

## Mechanical Characteristics

- ◆ Package: DFN2010-5
- ◆ Case Material: "Green" Molding Compound.
- ◆ Terminal Connections: See Diagram Below
- ◆ Marking Information: See Below

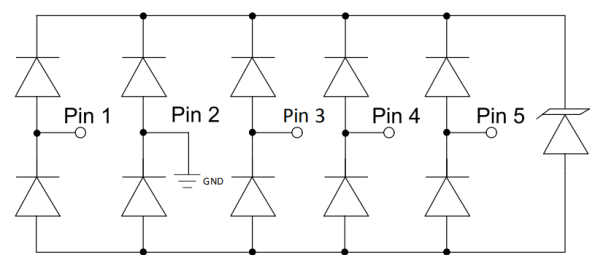

Circuit and Pin Schematic

## Features

- ◆ Ultra low capacitance: 0.2pF typical
- ◆ Ultra low leakage: nA level
- ◆ Operating voltage: 5V
- ◆ Low clamping voltage
- ◆ Complies with following standards:
  - IEC 61000-4-2 (ESD) immunity test
    - Air discharge:  $\pm 25\text{kV}$
    - Contact discharge:  $\pm 20\text{kV}$
  - IEC 61000-4-5 (Lightning) 3A (8/20) $\mu\text{s}$
- ◆ RoHS Compliant

## Applications

- ◆ Cellular Handsets and Accessories
- ◆ Display Ports
- ◆ MDDI Ports
- ◆ USB Ports
- ◆ Digital Visual Interface (DVI)
- ◆ PCI Express and Serial SATA Ports

## Dimensions and Pin Configuration

## Marking Information

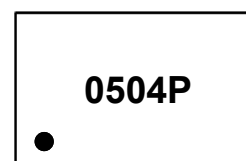

0504P = Device Marking Code

Dot denotes Pin 1

## Ordering Information

Part Number	Marking	Packaging	Reel Size
DL0504PCLV	0504P	10000/Tape & Reel	7 inch

### **Absolute Maximum Ratings ( $T_A=25^{\circ}\text{C}$ unless otherwise specified)**

Parameter	Symbol	Value	Unit
Peak Pulse Power (8/20 $\mu\text{s}$ )	Ppk	50	W
Peak Pulse Current (8/20 $\mu\text{s}$ )	I <sub>PP</sub>	3	A
ESD per IEC 61000-4-2 (Air)	V <sub>ESD</sub>	$\pm 25$	kV
ESD per IEC 61000-4-2 (Contact)		$\pm 20$	
Operating Temperature Range	T <sub>J</sub>	-55 to +125	$^{\circ}\text{C}$
Storage Temperature Range	T <sub>stg</sub>	-55 to +150	$^{\circ}\text{C}$

### **Electrical Characteristics ( $T_A=25^{\circ}\text{C}$ unless otherwise specified)**

Parameter	Symbol	Min	Typ	Max	Unit	Test Condition
Reverse Working Voltage	V <sub>RWM</sub>			5	V	
Breakdown Voltage	V <sub>BR</sub>	6			V	I <sub>T</sub> = 1mA
Reverse Leakage Current	I <sub>R</sub>			0.2	$\mu\text{A}$	V <sub>RWM</sub> = 5V
Clamping Voltage	V <sub>C</sub>			10	V	I <sub>PP</sub> = 1A (8 x 20 $\mu\text{s}$ pulse)
Clamping Voltage	V <sub>C</sub>			17	V	I <sub>PP</sub> = 3A (8 x 20 $\mu\text{s}$ pulse)
Junction Capacitance	C <sub>J</sub>		0.2		pF	V <sub>R</sub> = 0V, f = 1MHz

**Typical Performance Characteristics (TA=25°C unless otherwise Specified)**

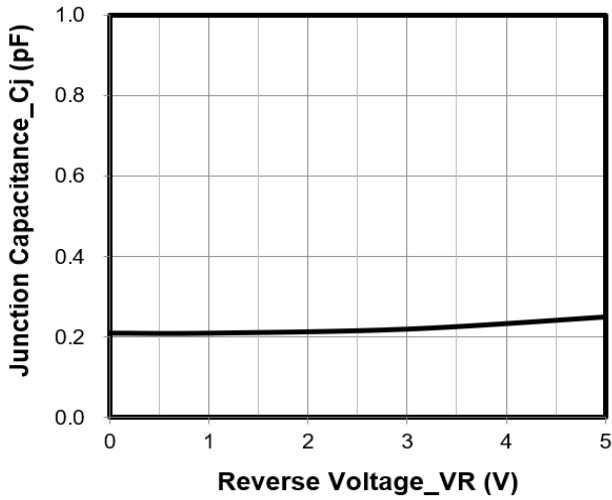

Junction Capacitance vs. Reverse Voltage

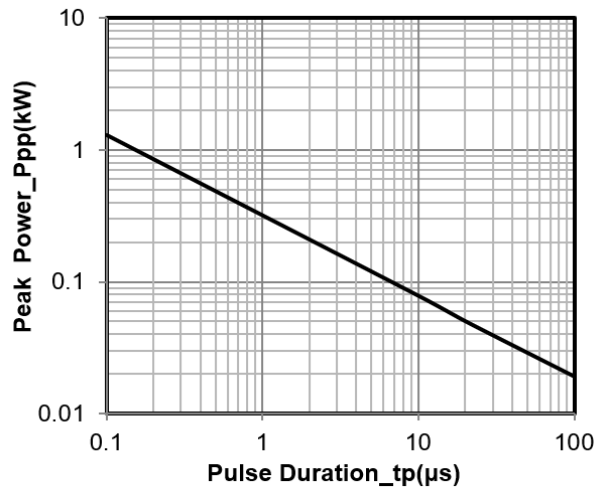

Peak Pulse Power vs. Pulse Time

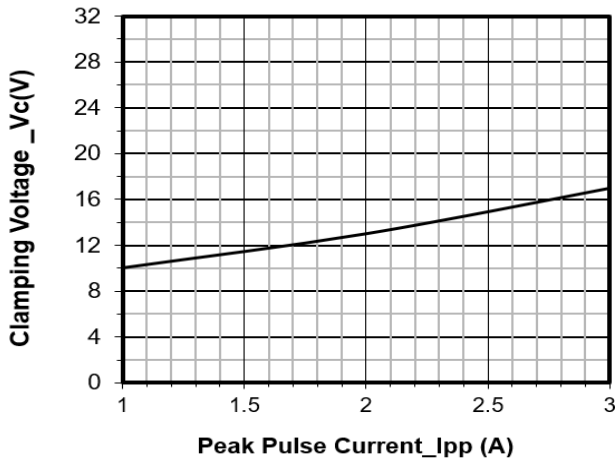

Clamping Voltage vs. Peak Pulse Current

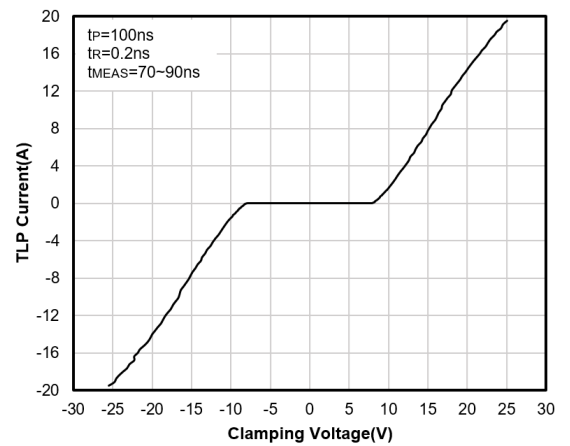

TLP Curve

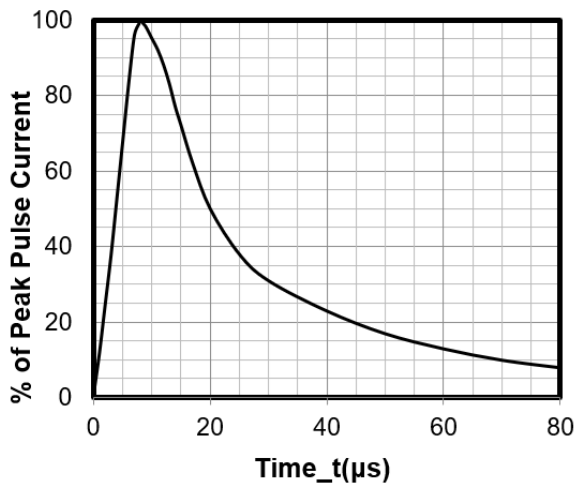

8 X 20μs Pulse Waveform

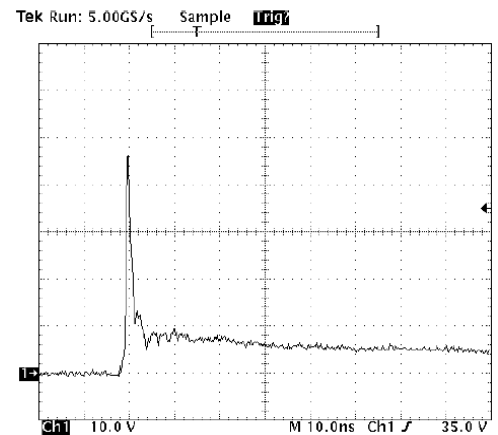

Note: Data is taken with a 10x attenuator

ESD Clamping Voltage

8 kV Contact per IEC61000-4-2

### DFN2010-5 Package Outline Drawing

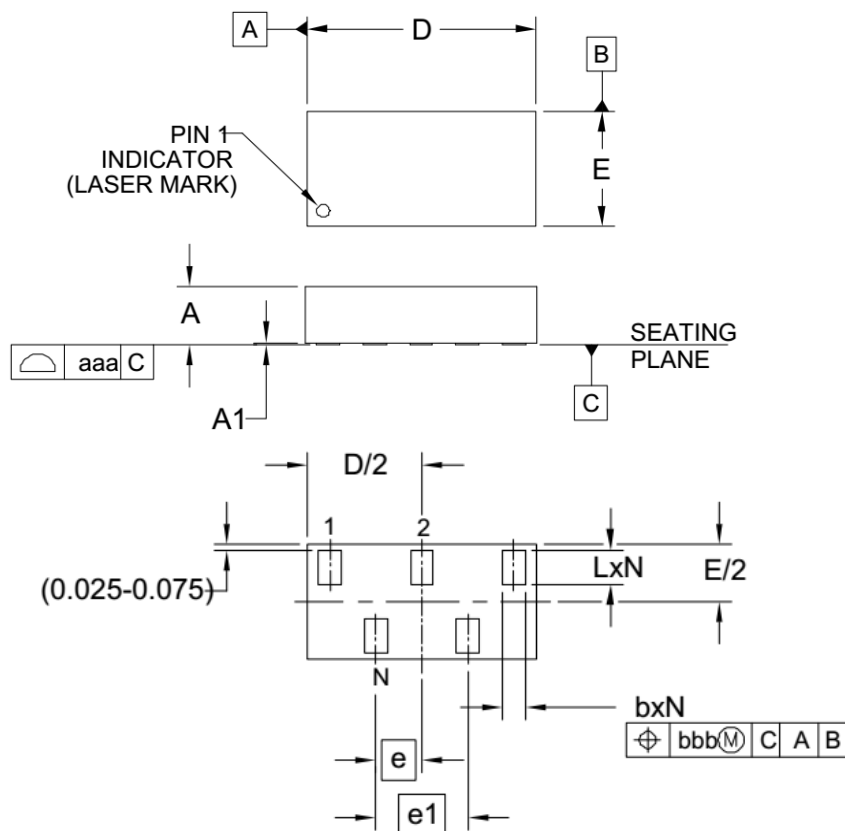

DIMENSIONS			
DIM	MILLIMETERS		
	MIN	NOM	MAX
A	0.45	0.50	0.55
A1	0.00	0.02	0.05
b	0.15	0.20	0.25
D	1.95	2.00	2.08
E	0.95	1.00	1.08
e	0.40 BSC		
e1	0.80 BSC		
L	0.25	0.30	0.35
N	5		
aaa	0.08		
bbb	0.10		

### Suggested Land Pattern

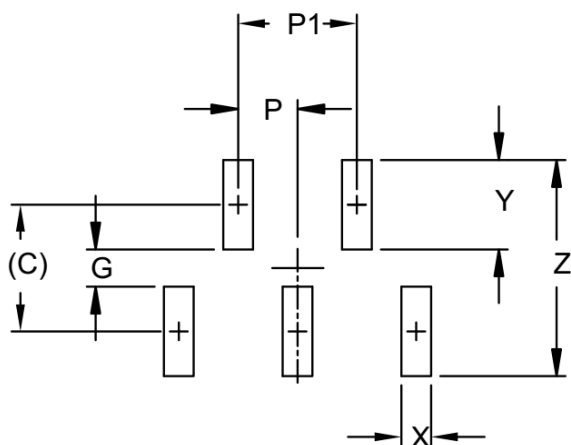

DIMENSIONS	
DIM	MILLIMETERS
C	(0.85)
G	0.25
P	0.40
P1	0.80
X	0.20
Y	0.60
Z	1.45

### Contact Information

Changzhou D-first Electronics CO.,Ltd.

www.first-electronic.com

Email: xhf@first-electronic.cn

Phone: +86 (0519) 8817 1671